

Flange Serrated Nut

Thread Type: Metric - Coarse

Thread Direction: Right Hand

Material: Carbon Steel

Class Grade: High Tensile Class 12

Finish: Zinc Flake Silver

Corrosion Protection Level: Excellent

Standard: HEC / CL12

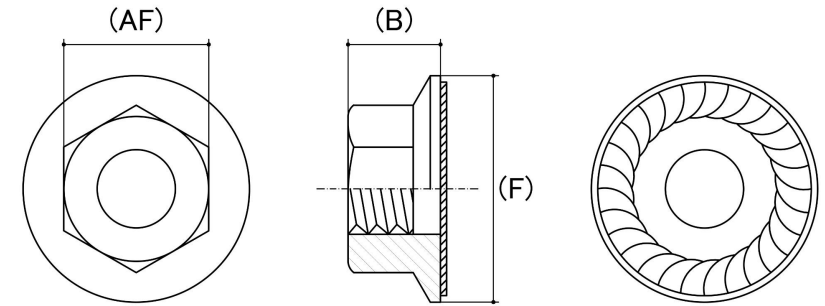

*CAD drawings shown for graphic representation only.**

Size	Thread Pitch (mm)	Thread Type	Overall Nut Height (B) (mm)	Flange Diameter (F) (mm)		Across Flats (AF) (mm)		Spanner Size (AF) (mm)	sku (qfind)
			Nom	Min	Max	Min	Max		
M8	1.25	Coarse	7.20	17.90	-	12.73	13.00	13	41FLD8ZF
M10	1.50	Coarse	9.15	21.50	21.80	14.73	15.00	15	41FLD10ZF
M12	1.75	Coarse	11.00	26.00	-	17.73	18.00	19	41FLD12ZF
M16	2.00	Coarse	16.00	32.00	-	23.73	24.00	24	41FLD16ZF
M20	2.50	Coarse	18.00	39.00	-	29.73	30.00	30	41FLD20ZF

Disclaimer:

Dimensional data and technical information was obtained from publically available sources and not acquired through standard agencies. It has been completed and compiled for reference purposes only; where discrepancies are found they are subject to change without notice. Bolt & Nut Australia makes no warranties or representations regarding the accuracy and validity of the compiled information and data. Contact the relevant standard authorities for accurate and detailed information.

* CAD drawings may not reflect diameter, thread length or overall length.

© Bolt & Nut Australia Pty Ltd. All rights reserved.

Version: 18 Mar 2024